

July 16-19, 2006 PORTO-PORTUGAL

**IABMAS'06**

Third International Conference on Bridge Maintenance, Safety and Management

**Title** Use of Mobile Measuring System for Bridge Monitoring

**Authors** V.N. Fedoseyev, GUP "Gormost", E. Brodskaja AGA Group, Inc



International Association for  
Bridge Maintenance and Safety

## Schematic diagram of the equipment suitable for the implementation of such technology

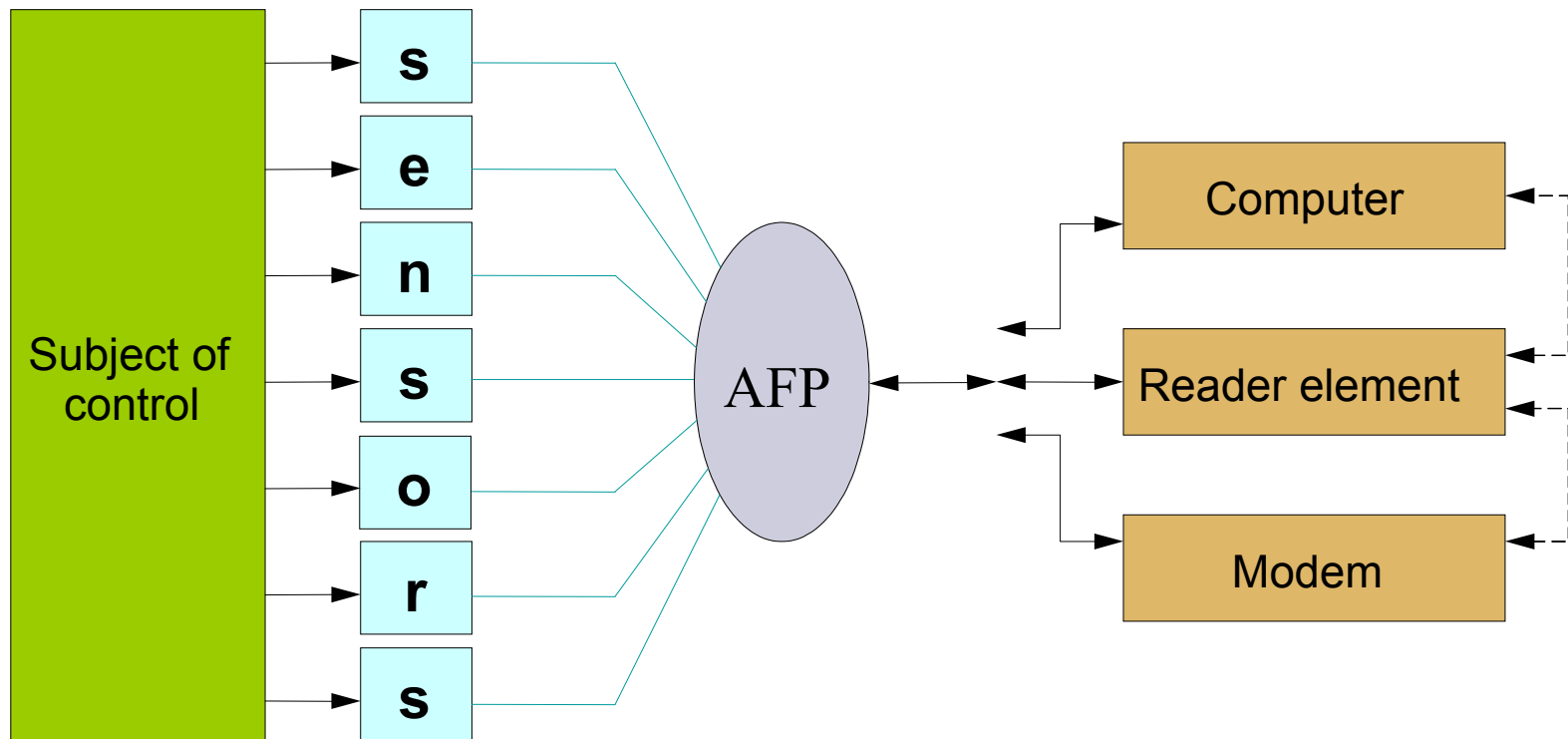

## Graphical representation of AFPy measurement results in Electronic Recorder mode in terms of temperature measurement (primary transducer - Omega 44030 thermistor).

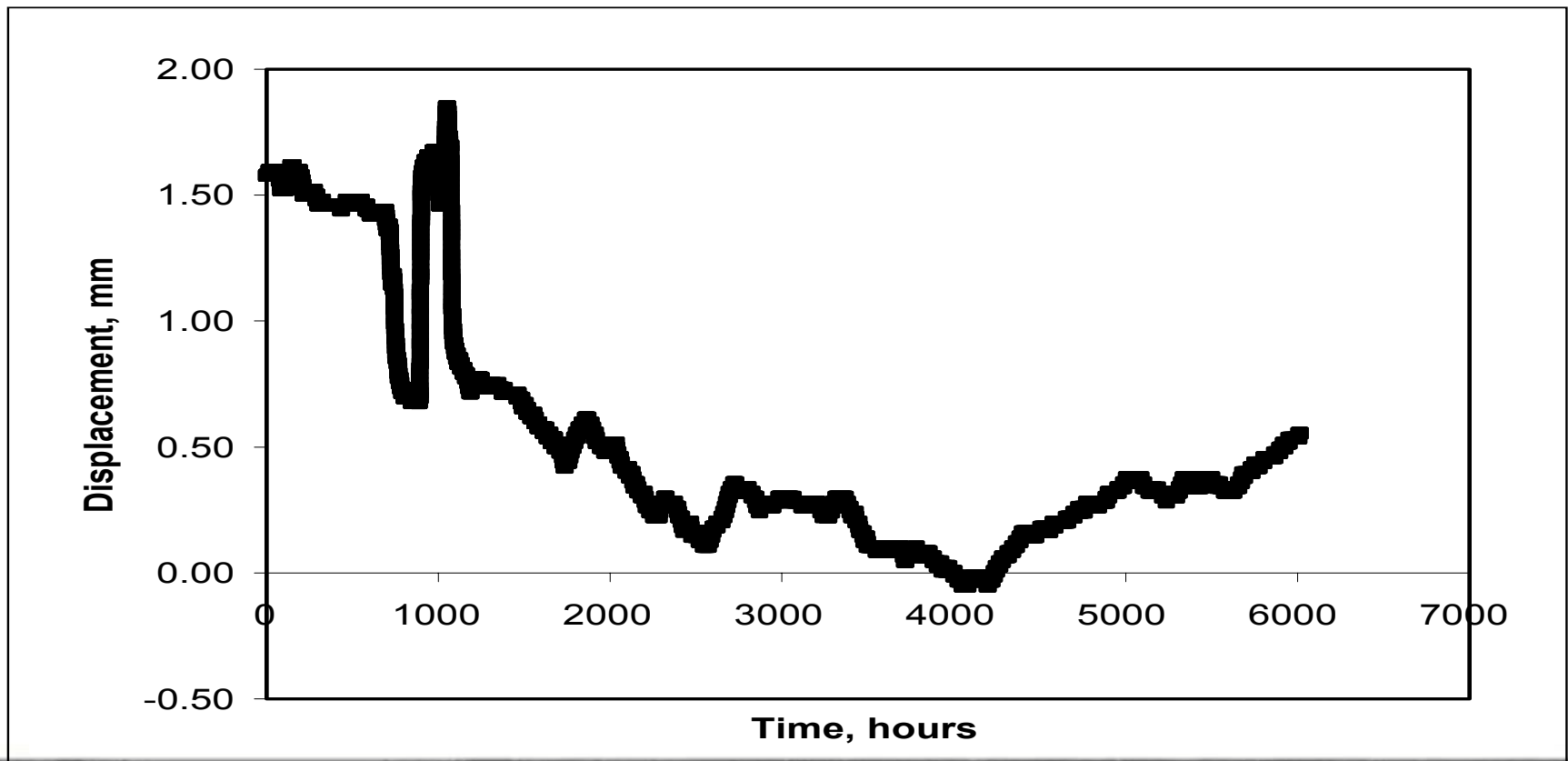

**Graphical representation of AFPy measurement results in Data Logger mode in terms of the liquid differential pressure (primary transducers—MD-400P).**

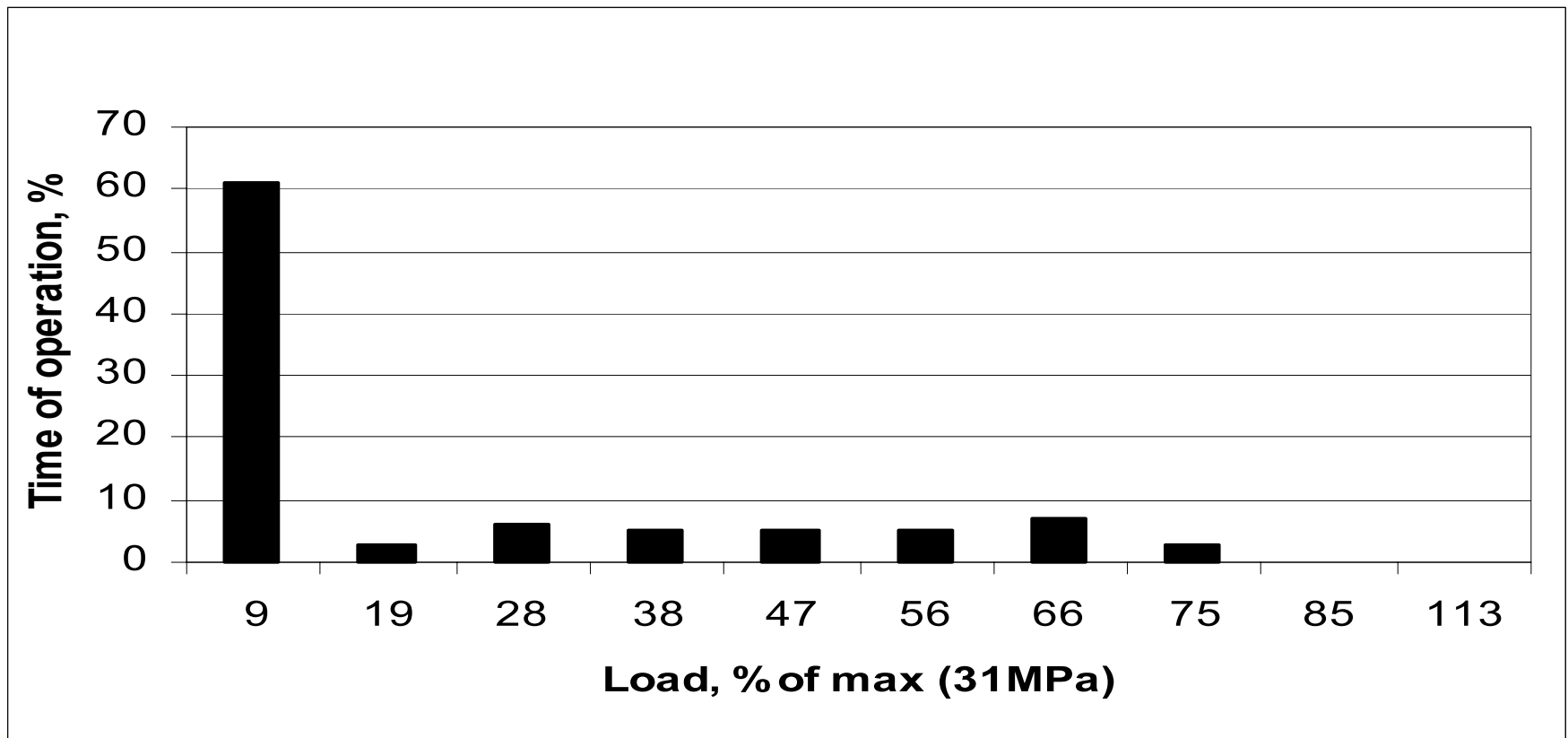

## Examples of linear displacement sensors usage

Avtozavodski bridge.

Monitoring aim – control of consoles vertical displacement after major overhaul

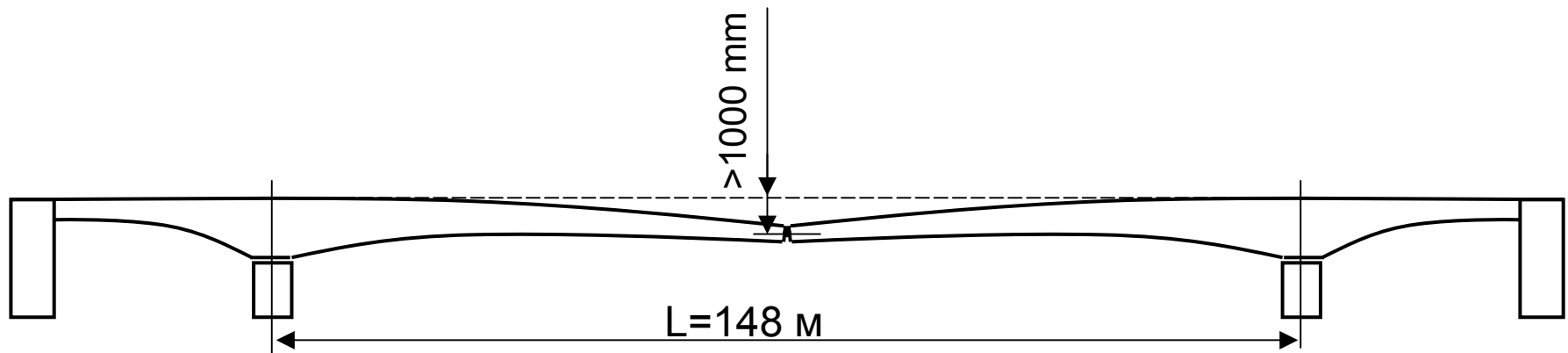

## Avtozavodski bridge. Overhaul stages

Reinforcing consoles with strained armature

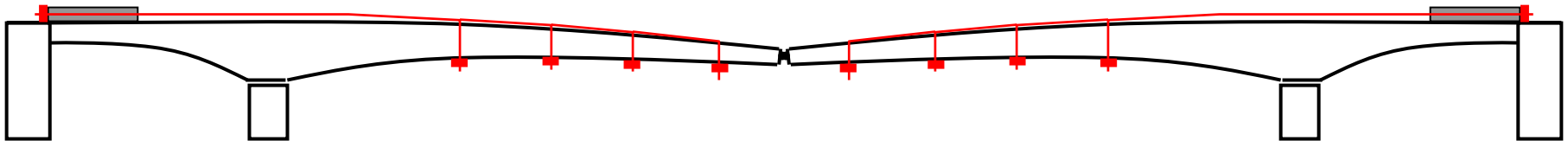

Profile correction by turning the flying structures

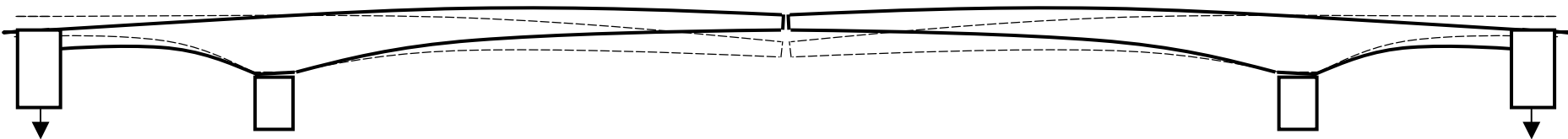

## Avtozavodski bridge. Technique of vertical displacement monitoring during operation stage

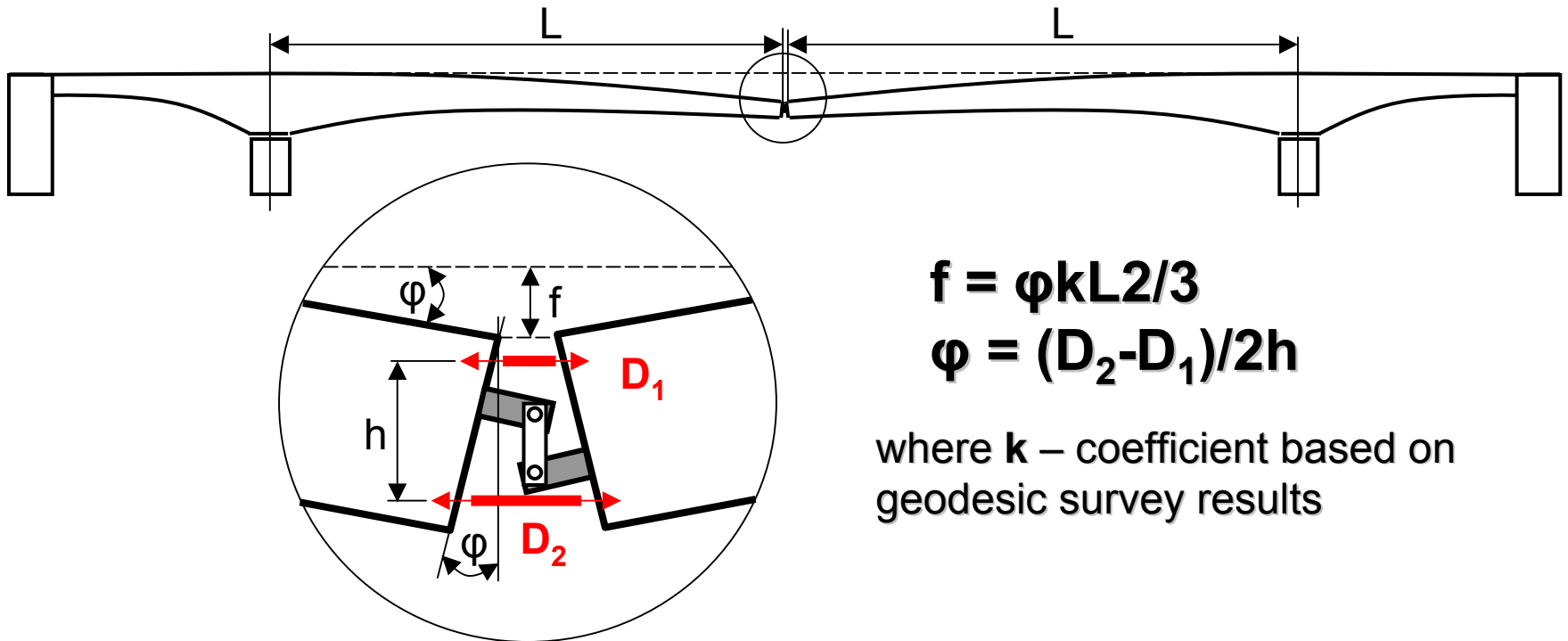

$$f = \phi k L^2 / 3$$

$$\phi = (D_2 - D_1) / 2h$$

where  $k$  – coefficient based on geodesic survey results

## Avtozavodski bridge. Horizontal displacement in hinges

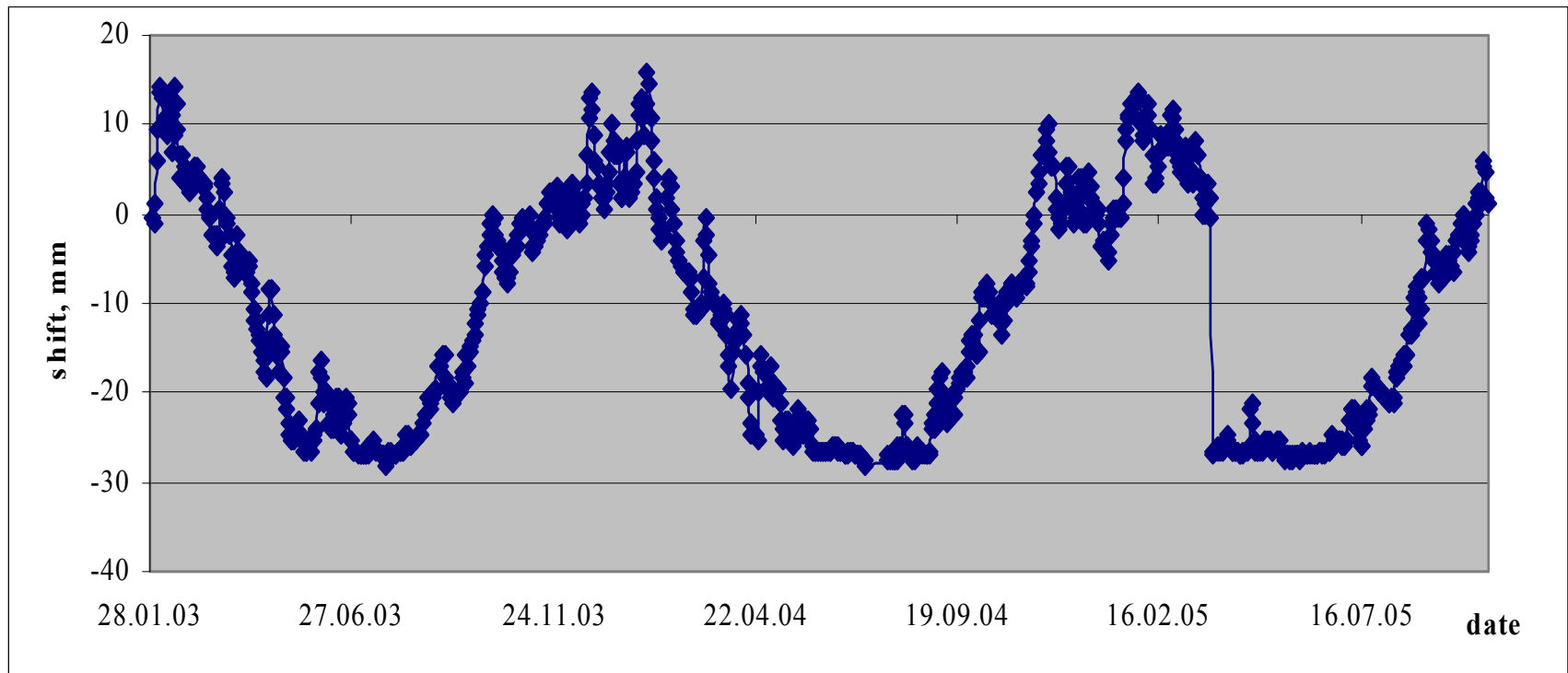

## Avtozavodski bridge. Vertical displacement of console edges (sagging)

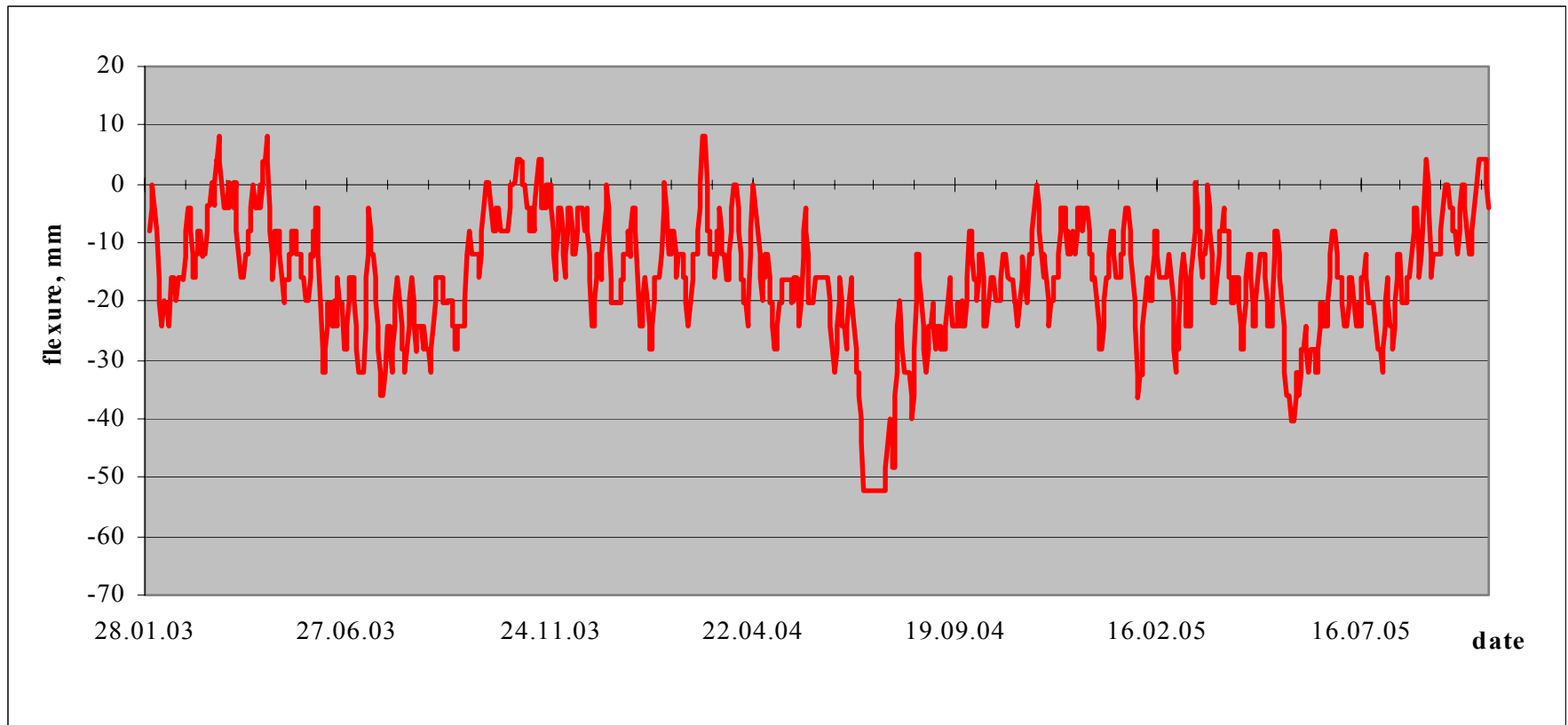

## Avtozavodski bridge. Seasonal fluctuation of temperature and displacement

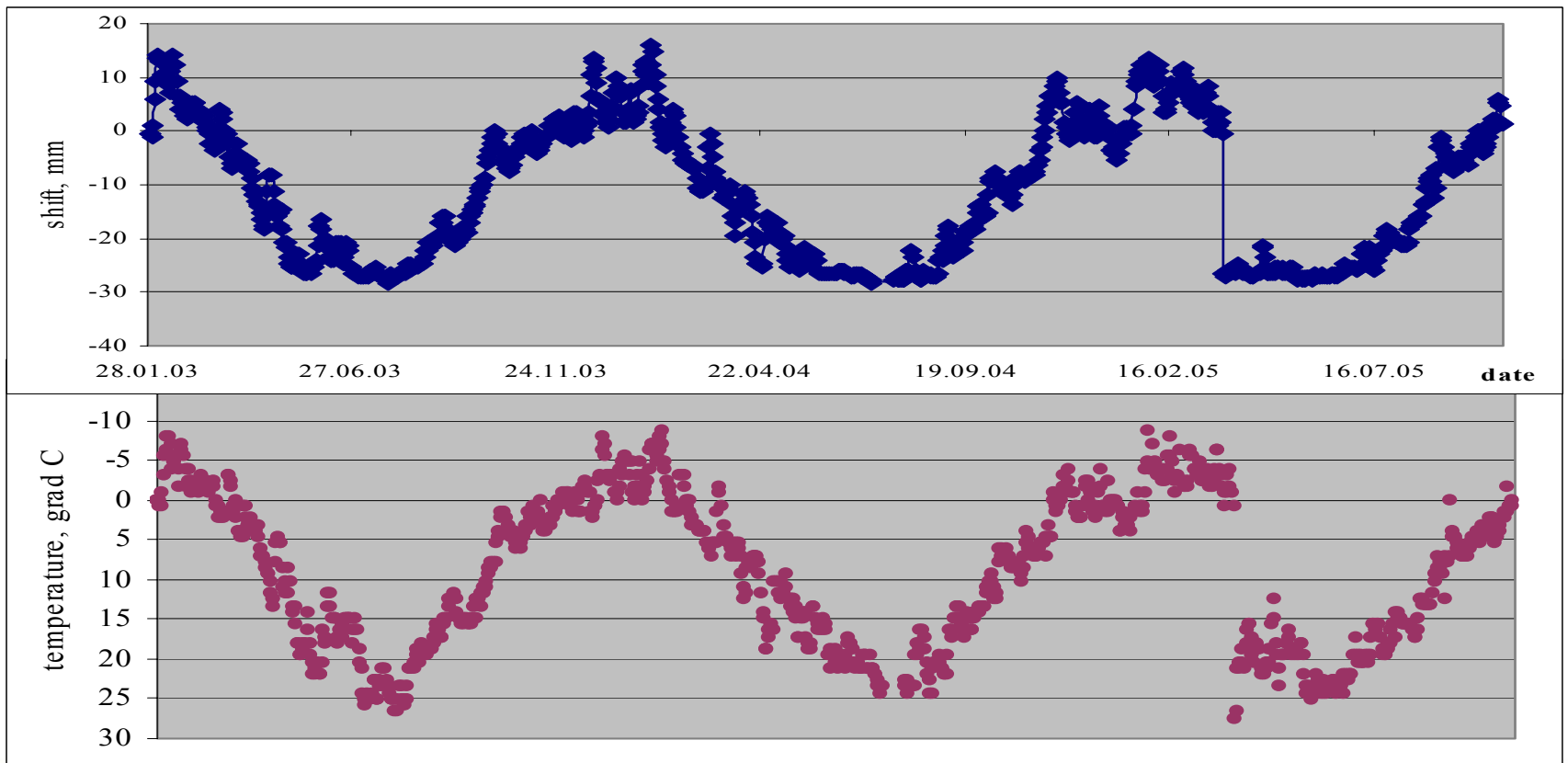



# IABMAS'06

## **Bolshoi Moskvoretski bridge. Seasonal fluctuation of temperature and displacement**



**Title** Use of Mobile Measuring System for Bridge Monitoring  
**Authors** V.N. Fedoseyev, GUP "Gormost", E. Brodskaia, AGA Group, Inc

## Bolshoi Moskvoretski bridge. Measurement of angular displacement in hinges

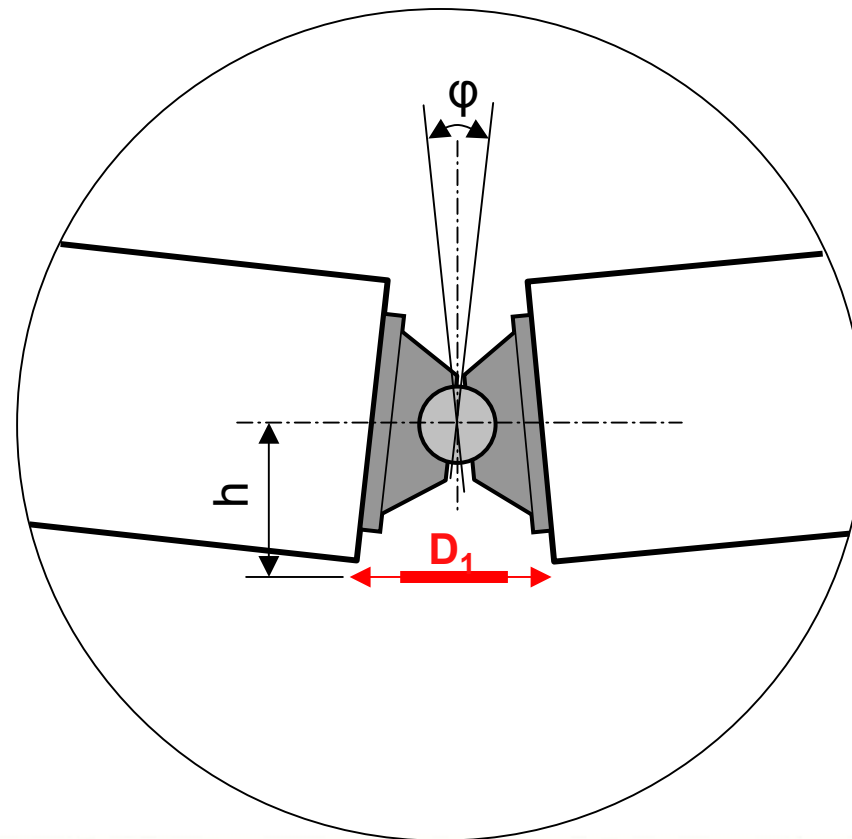

$$\phi = (D_0 - D_i) / h$$

## Bolshoi Moskvoretski bridge. Calculation of vertical and horizontal displacement in hinges.

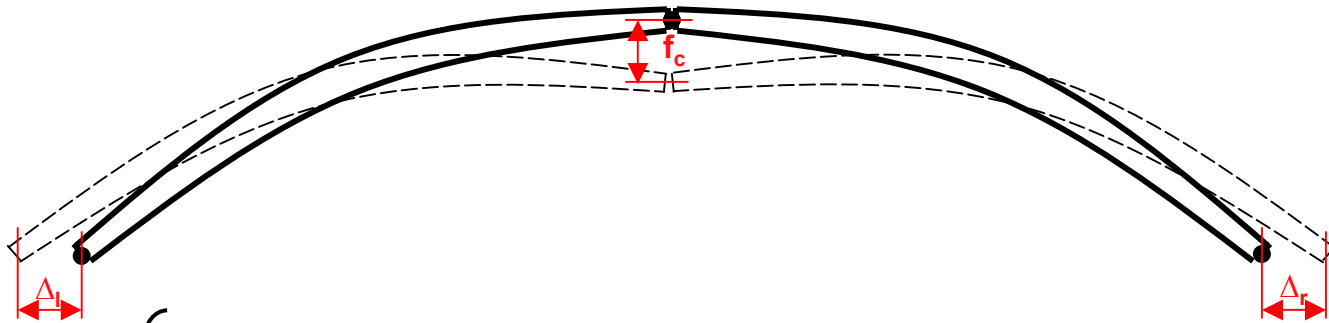

$$\begin{cases} \varphi_l = k_{ll} * \Delta_l + k_{lc} * f_c + k_{lr} * \Delta_r \\ \varphi_c = k_{cl} * \Delta_l + k_{cc} * f_c + k_{cr} * \Delta_r \\ \varphi_r = k_{rl} * \Delta_l + k_{rc} * f_c + k_{rr} * \Delta_r \end{cases}$$

## Bolshoi Moskvoretski bridge. Results of measuring displacement in hinges.

